



LP 400/500/600/700 Mustang 5100/8100 Airless Paint Sprayer

3A1185H

EN

For application of architectural paints and coatings. For professional use only. Not approved for use in European explosive atmosphere locations.

3000 psi (20.7 MPa, 207 bar) Maximum Working Pressure



Important Safety Instructions

Read all warnings and instructions in this manual. Save these instructions.

For model information, see page 2.

Related Manuals



Gun Manual

312363 - English
312364 - Spanish
312365 - French

Models

Vac	HiBoy	Stand	LoBoy
120V North America	24F568 LP500 - Series B 24F571 LP600 - Series B 24F581 Mustang 5100 - Series B 24F583 Mustang 8100 - Series B	24F567 LP500 - Series C 24F579 Mustang 5100 - Series C	24F569 LP500 - Series C 24F570 LP600 - Series C
240V Europe	16M373 LP500 - Series A 16M374 LP600 - Series A 16M375 LP700 - Series A	16M371 LP400 - Series A 16M372 LP500 - Series A	
110V UK	16M380 LP500 - Series A 16M381 LP600 - Series A 16M382 LP700 - Series A	16M378 LP400 - Series A 16M379 LP500 - Series A	
230V Australia	16M393 LP600 - Series A	16M389 LP400 - Series B 16M390 LP500 - Series B	16M391 LP500 - Series B 16M392 LP600 - Series B
230V Asia	17M002 LP600 - Series A	17M000 LP400 - Series A 17M001 LP500 - Series A	
230V CN	17M005 LP600 - Series A	17M003 LP400 - Series A 17M004 LP500 - Series A	

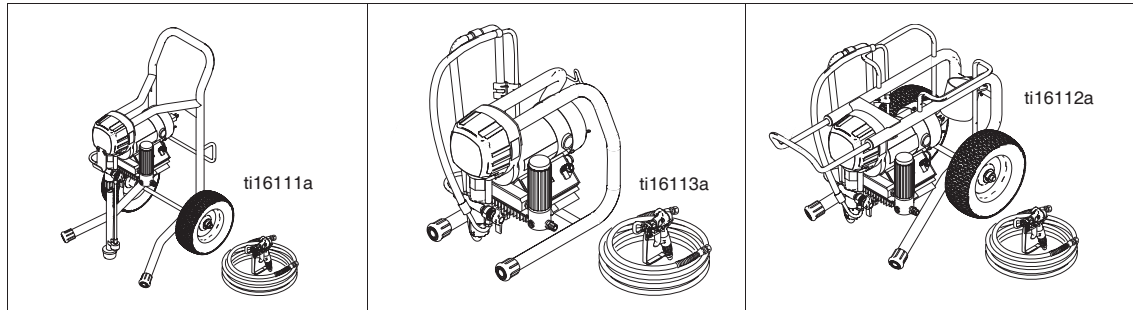

Warnings

The following warnings are for the setup, use, grounding, maintenance, and repair of this equipment. The exclamation point symbol alerts you to a general warning and the hazard symbols refer to procedure-specific risks. When these symbols appear in the body of this manual or warning labels, refer back to these Warnings. Product-specific hazard symbols and warnings not covered in this section may appear throughout the body of this manual where applicable.

WARNING



GROUNDING

This product must be grounded. In the event of an electrical short circuit, grounding reduces the risk of electric shock by providing an escape wire for the electric current. This product is equipped with a cord having a grounding wire with an appropriate grounding plug. The plug must be plugged into an outlet that is properly installed and grounded in accordance with all local codes and ordinances.

- Improper installation of the grounding plug is able to result in a risk of electric shock.
- When repair or replacement of the cord or plug is required, do not connect the grounding wire to either flat blade terminal.
- The wire with insulation having an outer surface that is green with or without yellow stripes is the grounding wire.
- Check with a qualified electrician or serviceman when the grounding instructions are not completely understood, or when in doubt as to whether the product is properly grounded.
- Do not modify the plug provided; if it does not fit the outlet, have the proper outlet installed by a qualified electrician.
- This product is for use on a nominal 120V or 230V circuit and has a grounding plug similar to the plug illustrated in the figure below.

120V US

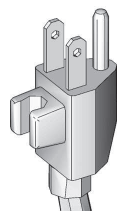

230V

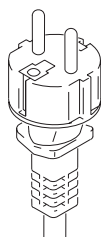

- Only connect the product to an outlet having the same configuration as the plug.
- Do not use an adapter with this product.

Extension Cords:

- Use only a 3-wire extension cord that has a 3-blade grounding plug and a 3-slot receptacle that accepts the plug on the product.
- Make sure your extension cord is not damaged. If an extension cord is necessary, use 12 AWG (2.5 mm²) minimum to carry the current that the product draws.
- An undersized cord results in a drop in line voltage and loss of power and overheating.

! WARNING



FIRE AND EXPLOSION HAZARD

Flammable fumes, such as solvent and paint fumes, in work area can ignite or explode. To help prevent fire and explosion:

- Do not spray flammable or combustible materials near an open flame or sources of ignition such as cigarettes, motors, and electrical equipment.
- Paint or solvent flowing through the equipment is able to result in static electricity. Static electricity creates a risk of fire or explosion in the presence of paint or solvent fumes. All parts of the spray system, including the pump, hose assembly, spray gun, and objects in and around the spray area shall be properly grounded to protect against static discharge and sparks. Use Airlessco conductive or grounded high-pressure airless paint sprayer hoses.
- Verify that all containers and collection systems are grounded to prevent static discharge.
- Connect to a grounded outlet and use grounded extensions cords. Do not use a 3-to-2 adapter.
- Do not use a paint or a solvent containing halogenated hydrocarbons.
- Keep spray area well-ventilated. Keep a good supply of fresh air moving through the area. Keep pump assembly in a well ventilated area. Do not spray pump assembly.
- Do not smoke in the spray area.
- Do not operate light switches, engines, or similar spark producing products in the spray area.
- Keep area clean and free of paint or solvent containers, rags, and other flammable materials.
- Know the contents of the paints and solvents being sprayed. Read all Material Safety Data Sheets (MSDS) and container labels provided with the paints and solvents. Follow the paint and solvents manufacturer's safety instructions.
- Fire extinguisher equipment shall be present and working.
- Sprayer generates sparks. When flammable liquid is used in or near the sprayer or for flushing or cleaning, keep sprayer at least 20 feet (6 m) away from explosive vapors.











ELECTRIC SHOCK HAZARD

This equipment must be grounded. Improper grounding, setup, or usage of the system can cause electric shock.

- Turn off and disconnect power cord before servicing equipment.
- Use only grounded electrical outlets.
- Use only 3-wire extension cords.
- Ensure ground prongs are intact on power and extension cords.
- Do not expose to rain. Store indoors.

! WARNING

	<p>SKIN INJECTION HAZARD</p> <p>High-pressure spray is able to inject toxins into the body and cause serious bodily injury. In the event that injection occurs, get immediate surgical treatment.</p> <ul style="list-style-type: none"> • Do not aim the gun at, or spray any person or animal. • Keep hands and other body parts away from the discharge. For example, do not try to stop leaks with any part of the body. • Always use the nozzle tip guard. Do not spray without nozzle tip guard in place. • Use Airlessco nozzle tips. • Use caution when cleaning and changing nozzle tips. In the case where the nozzle tip clogs while spraying, follow the Pressure Relief Procedure, page 8 for turning off the unit and relieving the pressure before removing the nozzle tip to clean. • Do not leave the unit energized or under pressure while unattended. When the unit is not in use, turn off the unit and follow the Pressure Relief Procedure, page 8 for turning off the unit. • Check hoses and parts for signs of damage. Replace any damaged hoses or parts. • This system is capable of producing 3000 psi. Use Airlessco replacement parts or accessories that are rated a minimum of 3000 psi. • Always engage the trigger lock when not spraying. Verify the trigger lock is functioning properly. • Verify that all connections are secure before operating the unit. • Know how to stop the unit and bleed pressure quickly. Be thoroughly familiar with the controls.
	<p>EQUIPMENT MISUSE HAZARD</p> <p>Misuse can cause death or serious injury.</p> <ul style="list-style-type: none"> • Always wear appropriate gloves, eye protection, and a respirator or mask when painting. • Do not operate or spray near children. Keep children away from equipment at all times. • Do not overreach or stand on an unstable support. Keep effective footing and balance at all times. • Stay alert and watch what you are doing. • Do not leave the unit energized or under pressure while unattended. When the unit is not in use, turn off the unit and follow the Pressure Relief Procedure, page 8 for turning off the unit. • Do not operate the unit when fatigued or under the influence of drugs or alcohol. • Do not kink or over-bend the hose. • Do not expose the hose to temperatures or to pressures in excess of those specified by Airlessco. • Do not use the hose as a strength member to pull or lift the equipment.
	<p>PRESSURIZED ALUMINUM PARTS HAZARD</p> <p>Use of fluids that are incompatible with aluminum in pressurized equipment can cause serious chemical reaction and equipment rupture. Failure to follow this warning can result in death, serious injury, or property damage.</p> <ul style="list-style-type: none"> • Do not use 1,1,1-trichloroethane, methylene chloride, other halogenated hydrocarbon solvents or fluids containing such solvents. • Many other fluids may contain chemicals that can react with aluminum. Contact your material supplier for compatibility.

 WARNING	
 	<p>MOVING PARTS HAZARD Moving parts can pinch, cut or amputate fingers and other body parts.</p> <ul style="list-style-type: none"> • Keep clear of moving parts. • Do not operate equipment with protective guards or covers removed. • Pressurized equipment can start without warning. Before checking, moving, or servicing equipment, follow the Pressure Relief Procedure, page 8 and disconnect all power sources.
	<p>TOXIC FLUID OR FUMES HAZARD Toxic fluids or fumes can cause serious injury or death if splashed in the eyes or on skin, inhaled, or swallowed.</p> <ul style="list-style-type: none"> • Read MSDSs to know the specific hazards of the fluids you are using. • Store hazardous fluid in approved containers, and dispose of it according to applicable guidelines.
	<p>PERSONAL PROTECTIVE EQUIPMENT You must wear appropriate protective equipment when operating, servicing, or when in the operating area of the equipment to help protect you from serious injury, including eye injury, hearing loss, inhalation of toxic fumes, and burns. This equipment includes but is not limited to:</p> <ul style="list-style-type: none"> • Protective eyewear, and hearing protection. • Respirators, protective clothing, and gloves as recommended by the fluid and solvent manufacturer.
	<p>CALIFORNIA PROPOSITION 65 The engine exhaust from this product contains a chemical known to the State of California to cause cancer, birth defects or other reproductive harm.</p>

Component Identification

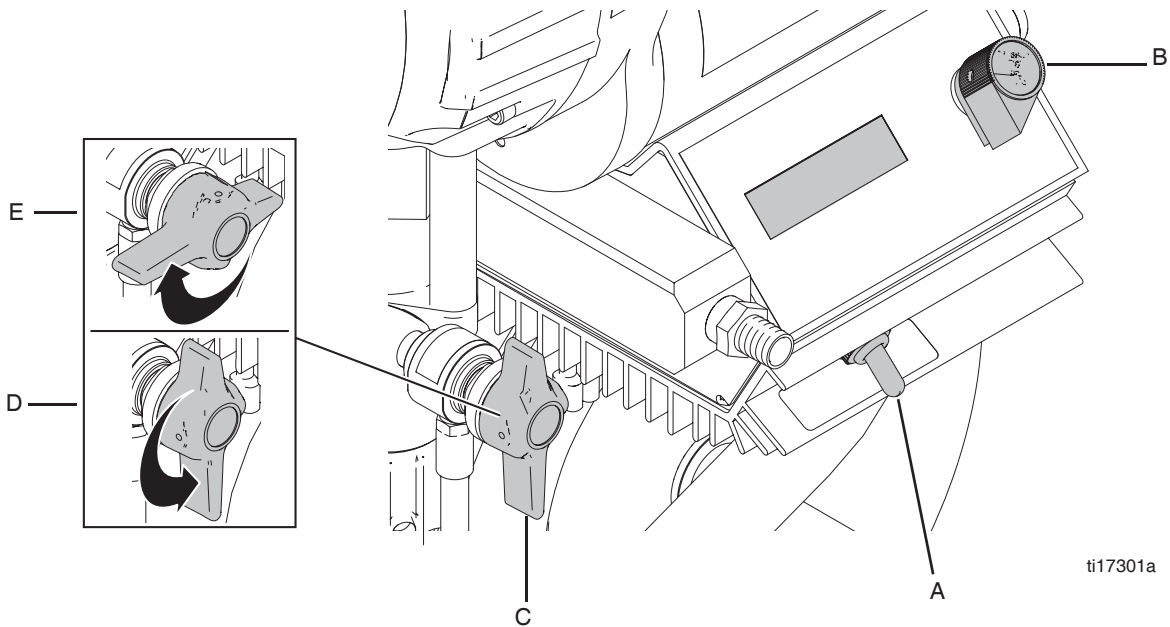

ti17301a

A	Power switch	Turns sprayer ON and OFF
B	Pressure Control Knob	Adjusts pressure. Turn clockwise to increase pressure and counterclockwise to decrease pressure.
C	Prime/Pressure Relief Valve	Primes pump and relieves pressure from gun, hose and tip.
D	Prime/Pressure Relief Valve Open Position	Relieves pressure from gun, hose and tip and primes the unit when in the open position. Valve is in open position when there is a wider gap between valve handle and cam body. Refer to Pressure Relief Procedure page 8.
E	Prime/Pressure Relief Valve Closed Position	Pressurizes system when closed. Valve is in closed position when there is a slight gap between valve handle and cam body.

Operation

Pressure Relief Procedure



Follow the Pressure Relief Procedure whenever you see this symbol.



This equipment stays pressurized until pressure is manually relieved. To help prevent serious injury from pressurized fluid, such as skin injection, splashing fluid and moving parts, follow the Pressure Relief Procedure when you stop spraying and before cleaning, checking, or servicing the equipment.

1. Engage the gun trigger lock. Refer to the separate instruction manual provided with gun for safety features and how to engage the trigger lock.
2. Turn the unit off.
3. Disengage the gun trigger lock and trigger the gun to relieve residual fluid pressure.

Hold metal part of the gun in contact with grounded metal pail. Use minimum pressure.

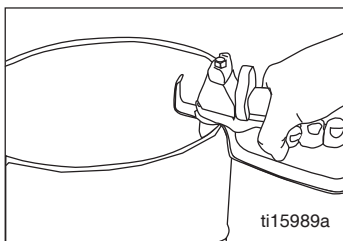

4. Re-engage gun trigger lock and turn Prime/Pressure Relief Valve (PR Valve) to the open (priming) position to relieve residual pressure.

Closed
(Pressure)

Open
(Priming and Pressure Relief)

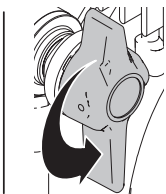
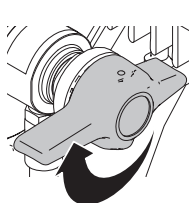

ti17403a

There will be a wider gap between valve handle and cam body when in open position. In the closed position there is only a very slight gap.

NOTE: The valve handle can move both clockwise and counter clockwise and can face different directions.

If the **spray tip or hose is clogged**, follow Steps 1 through 4 above. Expect paint to splash into the bucket while relieving pressure during Step 3.

NOTE: If you suspect that pressure hasn't been relieved due to damaged Prime/Pressure Relief Valve, or other reason, slowly loosen the tip nut or hose coupling to relieve pressure.

Setup



- To reduce the risk of static sparking, fire or explosion which can result in serious bodily injury and property damage. Always ground the sprayer and system components and the object being sprayed, as instructed in the safety warning section of this manual.
- Ensure proper electrical service and amperage and that the outlet is properly grounded.
- For generator power, a minimum 7000 watt generator with a voltage regulation must be used.

Connect the hose and gun

1. Remove the plastic cap plug from the outlet and screw a conductive or grounded 3000 psi spray hose onto fluid outlet.
2. Connect an airless spray gun to the other end of the hose. Do not install spray tip.

NOTE: Do not use thread sealer on swivel unions as they are made to self seal.

Fill the Packing Nut/Wet Cup

1. Remove guard and cap.
2. Fill the Packing Nut/Wet Cup with 5 drops of Airlessco Throat Seal Oil (TSO) or Packing Seal fluid.

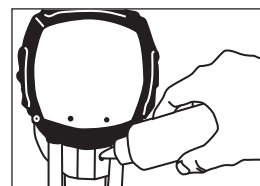

ti16049a

Flush the Sprayer

1. Flush the sprayer. See **Flushing Procedure** on page 9.

Prime and Flush Storage Fluid



NOTICE
The equipment was tested with lightweight oil, which is left in the fluid passages to protect parts. To avoid contaminating your fluid with oil, flush the equipment with a compatible solvent before using the equipment for the first time.

Before beginning a new spraying project you need to prime the sprayer and flush the storage fluid out of the sprayer.

Oil- or Water-based Materials

- When changing from water-based material to oil based material, flush with soapy water and then mineral spirits.
- When changing from oil based material to water base material, flush with mineral spirits, followed by soapy water, then a clean water flush.
- When flushing with solvents, ground pail and gun.
- Flush before changing colors, before fluid can dry in the equipment, at the end of the day, before storing, and before repairing equipment.

Flushing

						
<ul style="list-style-type: none"> • To reduce the risk of static sparking, which can cause fire or explosion, always hold a metal part of the gun firmly against the metal pail when flushing. This also reduces splashing. • Always remove the spray tip before flushing. 						

1. Make sure the gun trigger lock is engaged and there is no spray tip in the gun. Refer to the separate

instruction manual provided with gun for safety features and how to engage the trigger lock.

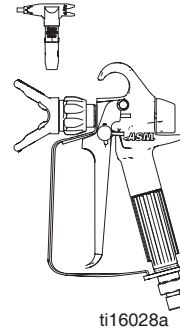

2. Pour enough clean, compatible solvent into a large, empty metal pail to fill the pump and hoses.
3. Place the suction tube into the pail or place the pail under the pump.
4. Turn Pressure Control Knob to low.

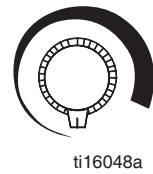

High Pressure

5. Open the prime/pressure relief valve to the open - "Priming Position". This will allow an easy start.

Closed (Pressure)

Open (Priming and Pressure Relief)

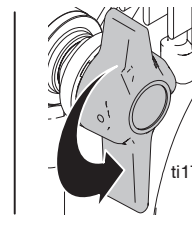
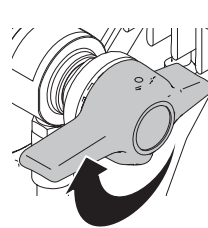

6. Turn the engine ON/OFF switch to ON.
7. Point the gun into the metal pail and hold a metal part of the gun firmly against the pail. Maintain firm metal to metal contact between gun and container.

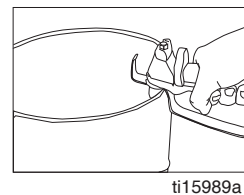

8. Disengage the gun trigger lock and squeeze the trigger. At the same time, slowly turn the pressure

control knob clockwise, just enough to move liquid at low pressure.

9. Allow the pump to operate until clean solvent comes from the gun.
10. Release the trigger and engage the gun trigger lock.
11. If you are going to start spraying, place the pump or suction tube into the supply container. Release the gun trigger lock and trigger the gun into another empty, metal container, holding a metal part of the gun firmly against the metal pail, forcing the solvent from the pump and hose. When paint starts coming from gun, turn pressure control knob to minimum pressure, place prime/pressure relief valve in prime (open) position and engage the gun trigger lock.
12. If you are going to store the sprayer, remove the suction tube or pump from the solvent pail, force the solvent from the pump and hose. Engage the gun trigger lock. See **Storage**, page 11.
13. Whenever shutting down the sprayer, follow **Pressure Relief Procedure**, page 8.



NOTICE

To prevent damage and freezing during storage, never leave water in the fluid pump

Startup

1. Prepare the material according to the material manufacturer's recommendations.
2. Place the suction tube into the material container.
3. Start the sprayer.
 - a. Prime/PR Valve must be "OPEN" in the priming position.
 - b. After ensuring the gun trigger lock is engaged, attach tip and safety guard.
 - c. Turn the engine ON/OFF switch to the "ON" position.
 - d. Turn the Pressure Control Knob clockwise to prime the pump.
 - e. After the pump is primed, turn the Prime/PR Valve to the "CLOSED" position.
 - f. Turn Pressure Control Knob to the desired spray pressure.
 - g. Disengage the gun trigger lock to begin spraying.

Adjusting the Pressure

						
<ul style="list-style-type: none"> • To reduce the risk of injection, never hold your hand, body, fingers or hand in a rag in front of the spray tip when cleaning or checking for a cleared tip. Always point the gun toward the ground or into a waste container when checking to see if the tip is cleared or when using a self cleaning tip. • When you spray into the paint bucket, always use the lowest spray pressure and maintain firm metal to metal contact between the gun and container. • To stop the unit in an emergency, turn the engine off. Then relieve the fluid pressure in the pump and hose. See Pressure Relief Procedure, page 8 						

When adjusting the pressure, turn the Pressure Control Knob clockwise to increase pressure and counterclockwise to decrease pressure. Always use the lowest pressure necessary to completely atomize the material. If more coverage is needed, use a larger tip rather than increasing the pressure.

NOTE: Operating the sprayer at higher pressure than needed wastes material, causes early tip wear, and shortens sprayer life.

NOTE: Check the spray pattern. The tip size and angle determines the pattern width and flow rate.

Shutdown

1. **Relieve Pressure**, page 8.
2. Clean the tip and gun as recommended in the separate Gun Manual supplied with the gun.
3. If spraying water-based material or a material that could harden in the sprayer overnight, flush the sprayer after use. See **Flushing**, page 9.

Storage

Short Term

1. Flush sprayer with compatible solvent before storing, then fill the pump and hoses with an oil based solvent such as mineral spirits.
 - For oil base paint: flush with mineral spirits
 - For water-base paint: flush with water, then mineral spirits and leave the pump, hose and gun filled with mineral spirits.

Long Term

For longer storage, use Graco Pump Armor or mineral spirits. Shut off sprayer, Relieve Pressure, page 8, and make sure prime/pressure relief valve is left open.

Start Up After Storage

Before using water-base paint, flush sprayer with soapy water and then a clean water flush. When using oil-base paint, flush out the mineral spirits with the material to be sprayed.

NOTE: Always store unit indoors.

Maintenance

Daily Maintenance

1. Keep the displacement pump packing nut/wet cup lubricated with Airlessco TSO (Throat Seal Oil) at all times. The TSO helps protect the rod and packings.
2. Inspect the packing nut daily. If seepage of paint into the packing nut and/or movement of the piston upward is found (while not spraying), the packing nut should be tightened just enough to stop leakage. Overtightening will damage the packings and reduce the packing life.

Electric Motor Maintenance

Lubrication

The motor is supplied with pre-lubricated ball bearings, lubricated for the life of the bearing.

Motor Brushes

Motor brushes need periodic inspection and replacement as wear indicates. Standard brushes have an initial length of 1" and should be replaced when they are worn to a length of 1/2". Brush wear is greatly influenced by individual application and it is recommended that brush wear be checked at early intervals of operation in order to determine future required inspection.

To change the brushes:

1. Unplug the machine.
2. Remove the cover over the motor, if applicable.
3. Open the two covers at the rear of the motor.
4. Disconnect the brush wire.
5. Pull out the wire.
6. Push the brush retainer clip in and withdraw.
7. Remove the worn brushes.
8. Install new brushes in the reverse order.

To increase brush life, new brushes (Part #331780) need to have a run in period. After changing brushes, set the machine for spraying. With a bucket of Pump Conditioner and water, a 50' 1/4" airless hose, airless gun and tip on unit, open the prime/pressure relief valve and switch on. The pump will now prime. With pump running in the prime mode, turn the pressure control knob to high pressure. (The pump has to cycle fast with no pressure in the pump). Run the pump for 20 minutes and the brushes will be run in.



Servicing the Fluid Pump

Fluid Pump Disconnect

1. **Relieve Pressure**, page 8.
2. Flush the material you are spraying out of the machine.
3. Remove the connecting rod shield (12).
4. Move the piston rod (10) to its lowest position by cycling pump slowly.
5. Turn off the motor and disconnect power from unit.
6. Disconnect fluid tube (17) from pump body.
7. Remove the retaining ring (4) from the connecting rod (2) and slide the sleeve (3) down revealing the connecting rod pin (1).
8. Remove the suction tube assembly from the fluid pump (9) by unscrewing the suction nut (7) with the packing adjustment tool. (865008).
9. Using a 1/2" wrench, unscrew the two bolts (8) from the cover assembly (14). The fluid pump (9) will be hanging loosely at this point.
10. Remove the connecting rod pin (1) out of the connecting rod (2), allowing the removal of the fluid pump (9) from the machine.

Fluid Pump Reinstall

1. Loosen the packing nut and ensure that the piston rod (10) is in its upper position in the fluid pump body, snap cap onto packing nut and slip the sleeve (3) and the retaining ring (4) over the piston rod (10).
2. Push the piston rod (10) up into the connecting rod (2) and align the holes. Insert the connecting rod pin (1) through the connecting rod (2) and piston. Slip the sleeve (3) up over the connecting rod pin (1) and insert the retaining ring (4) into the groove on the connecting rod (2).
3. Push the two bolts (8) through the tube spacers (11) and screw them into the cover assembly. Using a 1/2" wrench, tighten the two bolts (8) evenly (alternating between them) until you reach 20 ft-lbs (27.12 N.m).
4. Reassemble lower suction valve assembly by placing the suction seat, O-ring, suction ball and suction ball guide in the suction nut (7) and screw onto fluid pump body.

5. Reconnect the Fluid Tube (17) to the fluid pump body.
6. Start the machine and operate slowly to check the piston rod (10) for binding. Adjust the two bolts (8), holding the fluid pump body to the cover assembly, if necessary. This will eliminate any binding.
7. Tighten packing nut clockwise until resistance is felt against the Belleville Springs, go 3/4 of a turn more. Put five drops of Airlessco Throat Seal Oil in the packing nut.
8. Run the machine at full pressure for several minutes. Release the pressure by following the **Pressure Relief Procedure**, page 8, and readjust the packing nut per step 7 above.
9. Install the connection rod shield (12) so the small hole is in the upper right hand corner.

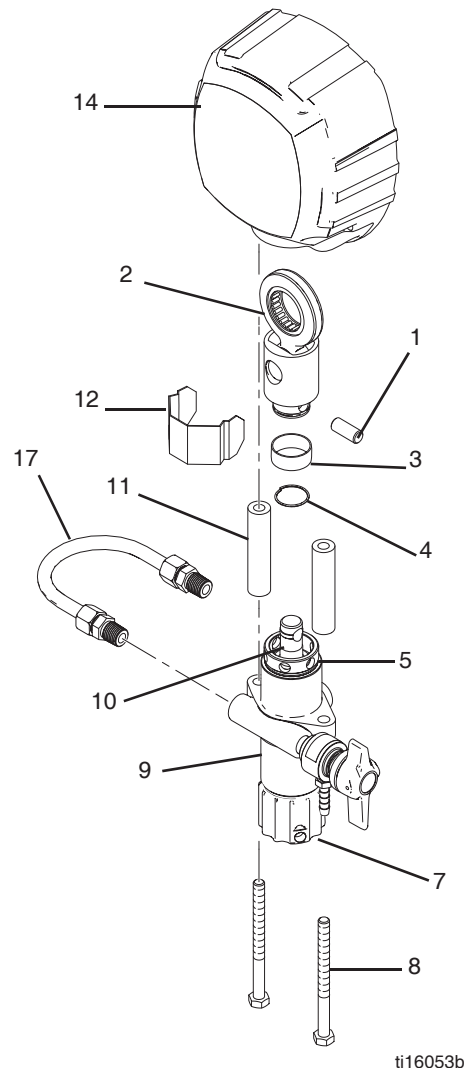

ti16053b

Servicing the Inlet Valve- Hi-Boy

1. Un-thread and remove suction nut from the fluid pump body (8).
2. Remove suction seat (12), O-ring (11), suction ball (10), and ball guide (9).
3. Clean all parts and inspect them for wear or damage, replacing parts as needed.
4. Clean inside of the fluid pump body (8).
5. Reassemble lower suction valve assembly by placing the suction seat (12), O-ring (11), suction ball (10) and suction ball guide (9) in the suction nut (13) and screw onto fluid pump body (8).

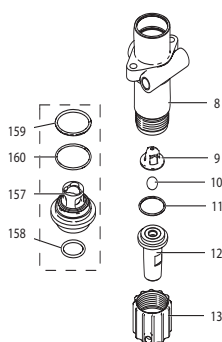

ti16115b

3. Push the piston rod down through the packings and out of the pump.
4. Now push the packing removal tool up through the pump and remove from the top bringing packings, spacer and springs along with it, leaving fluid body empty.
Make sure all old packings and glands have been removed from fluid pump.
5. Clean inside of fluid body.
6. Disassemble all parts and clean for reassembly. Discard any old packings.
7. Lubricate leather packing in lightweight oil for 10 minutes prior to reassembly.

Reassembly of the Fluid Pump

1. Place lower male gland(1) down on the flat side.
2. Take three of the lower polyethylene packings (2) and two of the leather packings (23) and place onto the male gland (1), with the inverted side down, in the following order:
 - Polyethylene
 - Leather
 - Polyethylene
 - Leather
 - Polyethylene
3. Take the female adaptor (3), which is inverted on both sides, and place it on top of your assembled lower packings.
4. Follow step 2 with your packings inverted side up.
5. Take the second lower male gland (1) and place it on top of your assembled packings with rounded side down.
6. Take assembled glands and packings (13 pieces) and slide onto the lower half of the piston (14).
7. Take the spacer (15) and slide over the top of the piston (14).
8. Take three spring washers (16) and slide over the top of the piston (14) in the following order:
 - First spring - curve facing up
 - Second spring - curve facing down
 - Third spring - curve facing up
9. Take the upper male gland (17) and place it rounded side up.

Servicing the Inlet Valve- Lo-Boy

1. Un-thread and remove suction nut from the fluid pump body (8).
2. Remove O-ring (158), suction seat assembly (157), O-ring (159) and backup (160).
3. Clean all parts and inside fluid body (8).
4. Reassemble inlet valve with O-ring (159), backup ring (160) and O-ring (158).
5. Tighten suction nut using packing adjustment tool (865008).

Packing Replacement Procedures

Disassembly of the Fluid Pump

1. **Disconnect the Fluid Pump**, page 12.
2. Unscrew and remove the packing nut, with wet cup cap.

10. Take three upper polyethylene packings (18) and two leather packings (22) and assemble with inverted side down, on to the male gland (17) in the following order:

- Polyethylene
- Leather
- Polyethylene
- Leather
- Polyethylene

11. Take upper female gland (19) and place on top of assembled upper packings with the inverted side down.

12. Take assembled upper glands and packings (7 pieces) and slide on over the top of the piston (14), making sure inverted sides are down.

13. Take the packing holder (20) and replace the white O-ring (24) and the black O-ring (25) with new ones from the packing kit.

14. Slide the packing holder (20) over the top of the upper packings so they fit inside.

15. Lubricate inside of the fluid pump body (4) and the outside of the packings with a light weight oil.

16. Slide assembly into fluid pump body.

NOTE: To keep packings secured in correct position, hold the pump body upside down and push the completed assembly upwards into the pump body. Once placed inside, tilt pump body back up to keep all pieces in.

17. Tighten packing nut (21) onto the top of the fluid pump body and tighten until you feel slight resistance against the Belleville Springs (16). Using the Packing Adjustment Tool, tighten another 3/4 of a turn.

18. Reinstall Fluid Pump, page 12.

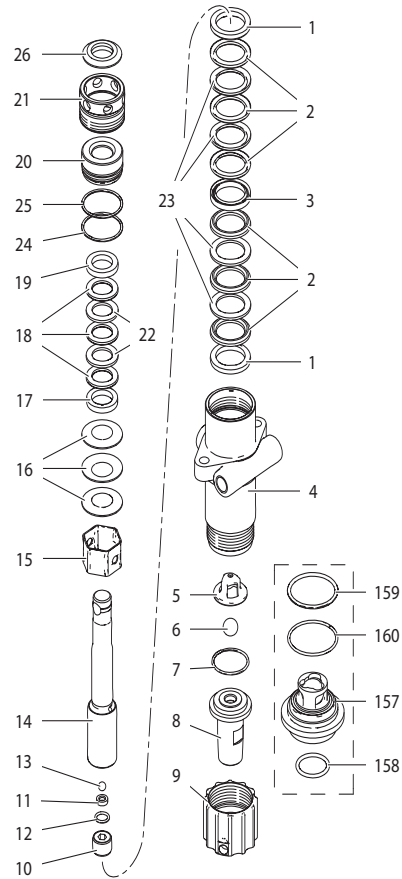

ti16056b

Gear and Pump Assembly

Servicing Gear box Assembly

1. Remove fluid pump. See **Fluid Pump Disconnect**, page 12.
2. Remove frame from the gearbox by loosening the four mounting screws.
3. Separate cover assembly (13) from box by removing bolts (1) from front of cover and back of box and shoulder bolts (2) from front of cover and back of box.
4. Lay unit on its back and disassemble gearbox.
5. Inspect bearings (14, 17), Crosshead Assembly (15), Gearcrank (16) and sleeve bearing (10) inside cover assembly (15) for wear/damage. Replace worn/damaged parts.
6. If gear grease needs replacing, replace with gear grease (Part No. 114819).
7. Clean mating surfaces of cover and box thoroughly. Apply Loctite® 518 on half the bottom surface of end bell.
8. Reassemble in reverse order.

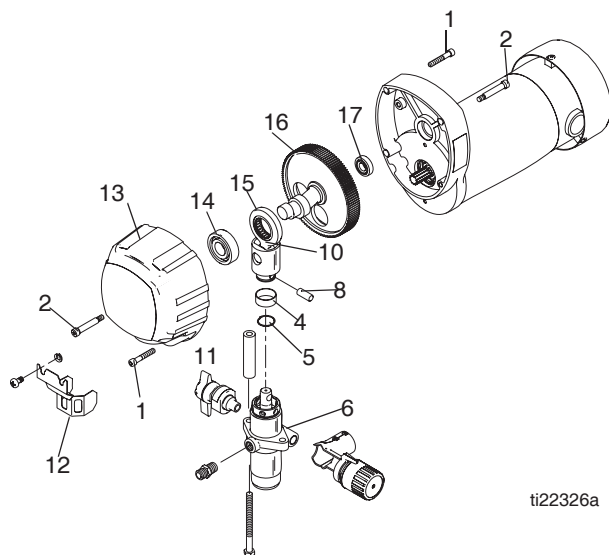

ti22326a

Replacement of Electrical Components

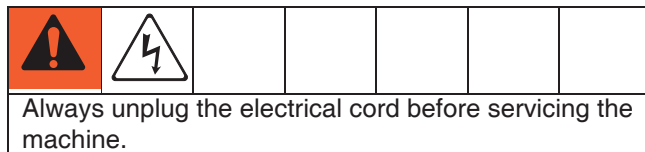

NOTE: Anytime the pressure control assembly, sensor, or both are replaced, perform the calibrations.

Pressure Control Assembly (Electrical Control Board)

1. Unplug machine's power cord.
2. Remove six screws heatsink housing.
3. Disconnect all leads from pressure control assembly.
4. Reassemble in reverse order.

NOTICE

Unit will not operate if wires are disconnected or pinched. Upon reassembly, ensure all wires are connected and not pinched.

Sensor

1. Remove the four screws, heatsink, and lower the pressure control assembly.
2. Disconnect sensor lead from the board.
3. Unscrew sensor by holding sensor with 3/4" wrench.
4. Reassemble in reverse order.

NOTICE

Unit will not operate if wires are disconnected or pinched. Upon reassembly, ensure all wires are connected and not pinched.

Potentiometer

1. Lower pressure control assembly as described above.
2. Disconnect potentiometer lead from pressure control assembly.
3. Use a 1/16" allen wrench, loosen set screw in the potentiometer knob and remove knob and spacer.
4. Using a 1/2" wrench or deep socket, remove the nut from the potentiometer shaft assembly.

Maintenance

5. Pull entire potentiometer assembly out of the terminal box.
6. Replace in reverse order.

NOTICE

Unit will not operate if wires are disconnected or pinched. Upon reassembly, ensure all wires are connected and not pinched.

On-Off Toggle Switch

1. Lower the pressure control assembly as described above.
2. Disconnect the two wires on the toggle switch.
3. Use a 9/16" wrench to loosen the nut on the toggle switch shaft.
4. Reassemble in reverse order.

NOTICE

Unit will not operate if wires are disconnected or pinched. Upon reassembly, ensure all wires are connected and not pinched.

Liquid Crystal Display (LCD)

1. Lower pressure control assembly as described above.
2. Unscrew the two nuts (M3) and remove LCD Display assembly.
3. If unable to loosen the two nuts, hold them and unscrew the two screws. Then remove the LCD Display Assembly.
4. Reassemble in reverse order, while making sure that the two spacers and the two washers are in place. Tighten the two nuts handtight and seal with blue loctite. **Do not** overtighten the nuts as this will damage the display.

NOTICE

Unit will not operate if wires are disconnected or pinched. Upon reassembly, ensure all wires are connected and not pinched.

Troubleshooting

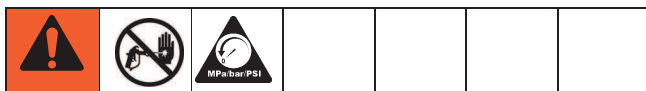



Problem	Cause	Solution
Unit doesn't prime	Airleak due to loose suction nut	Tighten suction nut.
	Airleak due to worn o-rings	Replace o-ring (108526) on suction seat and o-ring (867370) below suction seat.
	Airleak due to hole in suction hose	Replace suction hose.
	Stuck or fouled balls	Service inlet and outlet valves.
Unit primes but has poor or no pressure	Pressure set too low	Turn up pressure.
	Filter(s) are clogged	Clean or replace gun filter, inlet filter, and/or manifold filter.
	Outlet valve fouled/worn.	Service outlet valve.
	Prime/pressure relief valve bypassing	Clean or replace prime/pressure relief valve (866428).
	Packings and/or piston worn	Tighten packing nut, repack unit.
Unit does not maintain good spraying pressure	Blown spray tip	Replace spray tip.
	Packings and/or pistons worn	Repack unit.
	Upper seat worn	Replace upper seat.
Unit does not run	Blown fuse	Replace fuse 20A Slow Blow (331328).
Machine does not start	Control Settings	Make sure machine is plugged into the wall. Verify the on-off switch is in the ON position and the pressure control knob is turned all the way to the right (clockwise for maximum pressure).
	Pressure Control Assembly (Board)	If the power indicating light is still out after checking the control settings and power source, replace the pressure control assembly.

Problem	Cause	Solution
	Motor	<p>Remove the motor brush covers and turn the machine ON. Set the potentiometer (POT) at maximum pressure and check for DC voltage across both brush terminals. It should read greater than 80 volts DC.</p> <p>If you have DC voltage, turn the machine off and unplug it from the wall. Check to make sure the brushes are making good contact with the armature. Replace the brushes if they are less than 1/2" long. If the brushes are good, replace the motor.</p> <p>If you do not have DC voltage, see Sensor.</p>
	Sensor	<p>Plug another sensor board into the board and perform the zero calibration procedure. If the machine starts to run, the sensor is bad. If there is no replacement sensor available, use a multi-meter to test the resistance across the red and black wires of the sensor (be sure to test the plug). You should read 1.5 - 3.5k ohms. A faulty sensor usually reads no continuity (open).</p> <p>If the sensor passes all the tests, see Pressure Control Knob (Potentiometer).</p>
	Pressure Control Knob (Potentiometer)	<p>Plug another potentiometer (POT) into the control board. If the machine starts, the old POT is bad.</p> <p>When a replacement POT is not available, remove the POT lead (with the machine turned off) from the control board and test the resistance between the red and black wires (be sure to test at the plug). The resistance should read between 8-12k ohms. If it is outside of this range replace the POT.</p> <p>If there is DC voltage at the motor brushes and the sensor and pressure control knob are functioning, replace the pressure control assembly.</p>

Pressure Control Repair

Motor Control Board Diagnostics

						
Relieve pressure and unplug sprayer before servicing control board. See Pressure Relief Procedure , page 8.						



1. For sprayers with digital display, see **Digital Display Messages**, page 20
2. Remove four screws and cover.
3. Turn ON/OFF switch ON.
4. Observe LED operation and reference following table:

NOTE: Keep a new transducer on hand to use for test.

NOTICE
Do not allow sprayer to develop fluid pressure without transducer installed. Leave prime/pressure relief valve open if test transducer is used.

LED BLINKS	SPRAYER OPERATION	INDICATES	WHAT TO DO
Once	Sprayer runs	Normal operation	Do nothing
Two times repeatedly	Sprayer shuts down and LED continues to blink two times repeatedly	Run away pressure. Pressure greater than 4500 psi (310 bar, 31 MPa) or damaged pressure transducer.	Replace motor control board or pressure transducer.
Three times repeatedly	Sprayer shuts down and LED continues to blink four times repeatedly.	Pressure transducer is faulty or missing	Check transducer connection. Open prime/pressure relief valve. Substitute new transducer for transducer in sprayer. If sprayer runs, replace transducer.
Four times repeatedly	Sprayer shuts down and LED continues to blink four times repeatedly.	Line voltage is too high	Check for voltage supply problems
Five times repeatedly	Sprayer does not start or shuts down and LED continues to blink five times repeatedly	Motor fault	Check for locked rotor, shorted wiring or disconnected motor. Repair or replace failed parts.
Six times repeatedly	Sprayer shuts down and LED blinks six times repeatedly	Motor is too hot or there is a fault in the motor thermal device	Allow sprayer to cool. If sprayer runs correctly when cool, check motor fan function and air flow. Keep sprayer in cool location. If sprayer does not run when cool and continues to blink 6 times, replace motor.
Eight times repeatedly	Sprayer stops or does not run	High input voltage	Check power source for correct voltage

Digital Display Messages (Series B)

						
<p>No display does not mean that sprayer is not pressurized. Relieve pressure before repair. See Pressure Relief Procedure, page 8</p>						

DISPLAY	SPRAYER OPERATION	INDICATION	ACTION
No Display	Sprayer stops. Power is not applied. Sprayer may be pressurized.	Loss of power	Check power source. Relieve pressure before repair or disassembly.
3000 psi 210 bar 21 Mpa	Sprayer is pressurized. Power is applied. (Pressure varies with tip size and pressure control setting.)	Normal operation	Spray
E=02	Sprayer may continue to run. Power is applied.	Pressure greater than 4500 psi (310 bar, 31 MPa) or pressure transducer faulty	Replace pressure control board or pressure transducer
E=03	Sprayer stops. Power is applied.	Pressure transducer faulty, bad connection or broken wire.	Check transducer connection. Open prime/pressure relief valve. Substitute new transducer for transducer in sprayer. If sprayer runs, replace transducer.
E=04	Sprayer stops. Power is applied.	Line voltage too high	Check for voltage supply problem
E=05	Sprayer does not start or stops. Power is applied.	Motor fault / High Current	Check for locked rotor, shorted wiring or disconnected motor, frozen or stuck pump. Repair or replace failed parts.
E=06	Sprayer stops. Power is applied.	Motor is too hot	Allow sprayer to cool. If sprayer runs correctly when cool, check motor fan function and air flow. Keep sprayer in cool location. If sprayer does not run when cool and continues to blink 6 times, replace motor.
E=08	Sprayer stops or does not run.	Low input voltage	Check power source for correct voltage.
- - - -	Power is applied.	Pressure less than 200 psi (14 bar, 1.4 MPa)	Increase pressure if desired. Prime/pressure relief valve may be open.

Parts

Manifold Filter (866480)

Mustang 8100, LP600/700 HiBoy, LP600 LoBoy

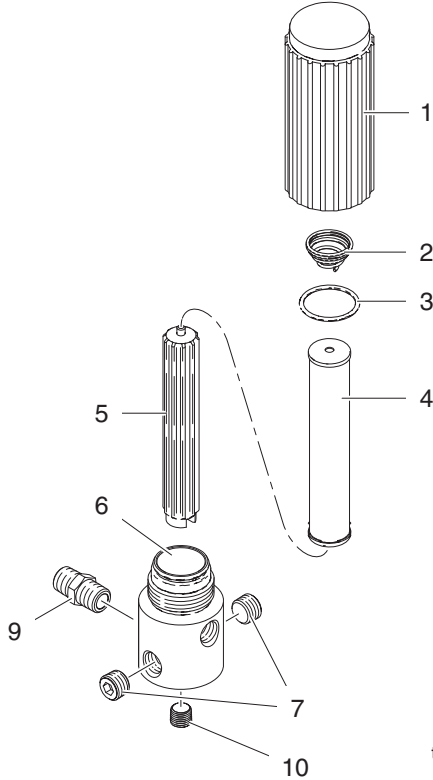

ti16052a

Ref.	Part	Description	Qty
1	867145	COVER	1
2	301356	SPRING	1
3	867377	O-RING	1
4	867214	FILTER 60 MESH	1
5	867647	SUPPORT	1
6	867077	BASE	1
7	867420	PLUG	2
9	867309	NIPPLE 3/8" M x 1/4" M	1
10	557391	PLUG 1/4"	1

Inlet Valve

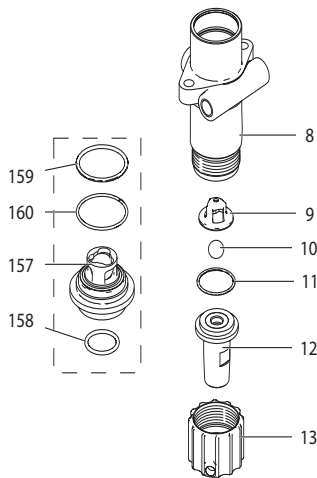

ti16115b

Ref.	Part	Description	Qty
8	331011	FLUID PUMP BODY	1
9	331029	SUCTION BALL GUIDE	1
10	331030	SUCTION BALL	1
11	108526	O-RING	1
12	331292	SUCTION SEAT (HI-BOY)	1
13	331034	SUCTION NUT	1
157‡		SUCTION SEAT ASSY (LO-BOY/STAND)	1
158*‡		O-RING	1
159*‡		O-RING	1
160*‡		RING, BACKUP	1

* Included in O-Ring Kit 16W484

‡ Included in Kit 331051.

Stand Frame Parts Diagram

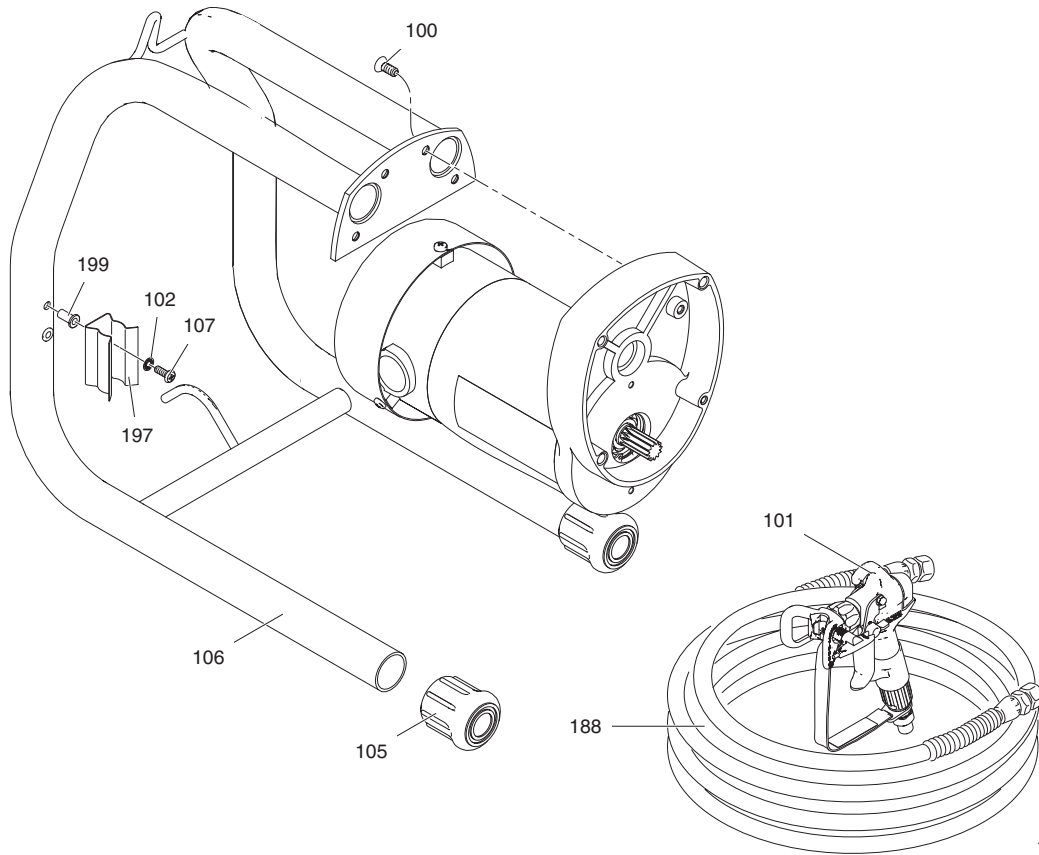

ti17479a

Ref. Part	Description	Qty	Ref. Part	Description	Qty
100	16F551 FASTENER,THREAD,EXTERNAL	4	188	HOSE 1/4" x 50	
101	GUN		HSE1450 (120V/230V)		1
	289316 500,2 FINGER,ASM, LP500 (120V/230V)	1	865674 (230/240V & 110V)		1
	289283 MODEL MUSTANG 5100	1	197 867622 SPRING,CLAMP PLATED		1
	24E514 SPRAY, 009, (230/240V & 110V)	1	199 867477 NUT, RIVNUT 10-24		2
102	140040 WASHER .392X.198X.045 .ZN	2	16F574 LABEL, FRONT, LP500 (not shown)		1
105	331048 RUBBER BOOT	2	16F735 LABEL, FRONT, MUSTANG 5100 (not shown)		1
106	331143 FRAME WELD LP CARRY	1	16F735 LABEL, FRONT, MUSTANG 5100 (not shown)		1
107	331342 SCREW,10-24 X.50 PH PN HD	2	16H948 LABEL, FRONT, LP400 (not shown)		1

LoBoy Frame Parts Diagram

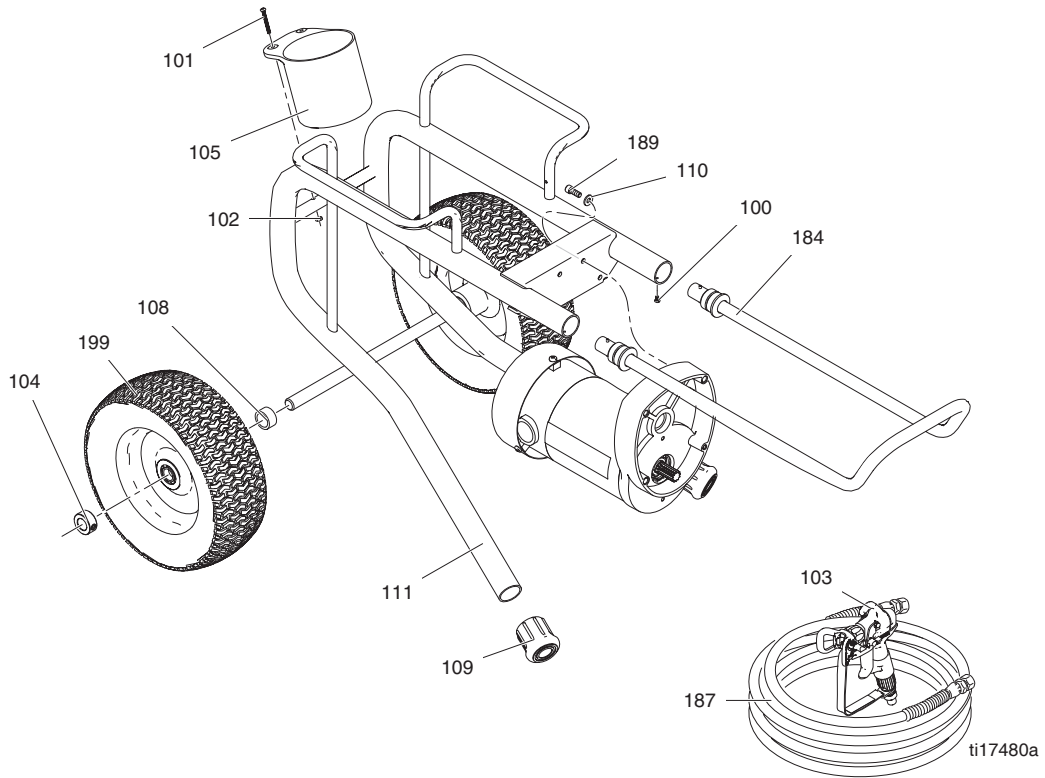

Ref.	Part	Description	Qty	Ref.	Part	Description	Qty
100	867488	SCREW #6X.25 SLFTAP PH HD	2	184a	331174	HANDLE	1
101	867551	SCREW 6-32X1.25 PH PN HD (120V/230V)	2	184b	331222	PIN	2
102	867329	NUT 6-32 X .109 TOP LOCK	2	184c	331175	SPACER	2
103		GUN		184d	331176	BUSHING	2
	289316	500,2 FINGER,ASM, (120V)	1	187		HOSE 1/4" X 50'	
	24E514	SPRAY, 009 (230/240V & 110V)			HSE1450 (120V)		1
104	143029	COLLAR,SCREW,SET (SPECIAL ID)	2		865674 (230/240V & 110V)		1
105	15B870	CUP,SUCTION/DRAIN	1	189	121112	SCREW,CAP, SOCKET HEAD	4
108	305039	SPACER,3/4 ID .50 LG PVC	2	199	867736	WHEEL-10" OD X3.5"W 150LB	2
109	331048	RUBBER BOOT	2		16F574	LABEL, LP500 FRONT (not shown)	1
110	331103	WASHER .562 .250 .060 .ST	4		16F575	LABEL, LP600 FRONT (not shown)	1
111	331171	FRAME WELD- LP-LB	1		16F576	LABEL, RIGHT, LP600 (not shown)	1
184	866476	HANDLE,LB,SUBASSEMBLY (Includes 184a, 184b, 184c, 184d)	1		16F577	LABEL, LEFT, LP600 (not shown)	
					16K914	LABEL, RIGHT, LP500 (not shown)	
					16K915	LABEL, LEFT, LP500 (not shown)	

Hi-Boy Parts Diagram

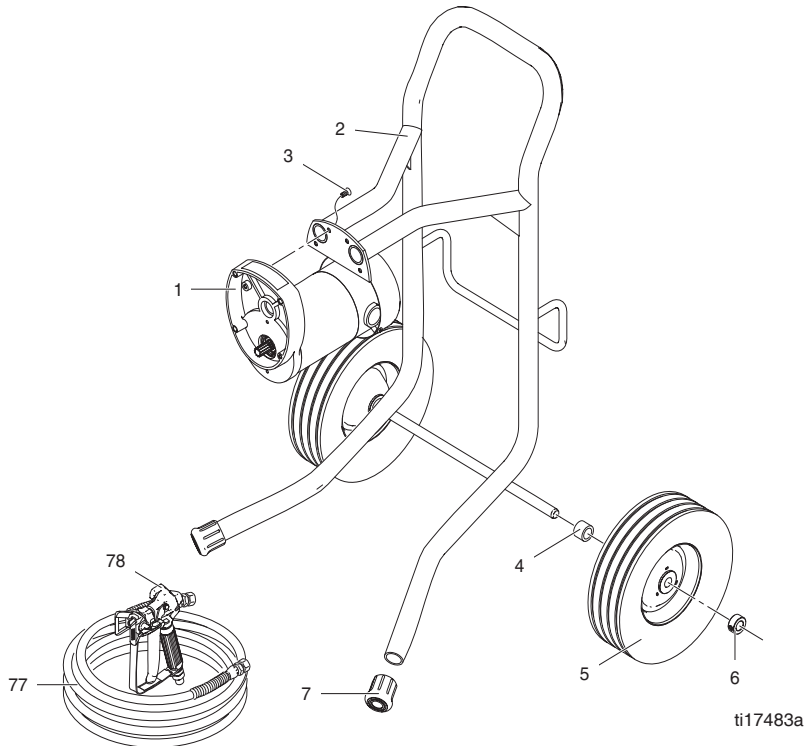

Ref.Part	Description	Qty	Ref.Part	Description	Qty
1	MOTOR		289316	500,2 FINGER,ASM, LP500 (120V/230V)	1
331490	.5HP, 110V: LP500 HIBOY/STAND, LP400 STAND	1	289283	MODEL MUSTANG 5100	1
331491	1HP, 110V: LP600/700 HIBOY, 120V: LP500/600 & MUSTANG 5100/8100	1	24E514	SPRAY, 009 (230/240V & 110V)	1
331492	.5HP, 230V: LP500 LOBOY, 240V: LP500 HIBOY, 230/240V: LP400/500 STAND	1	16F574	LABEL, FRONT, LP500 (not shown)	
331493	1HP, 230V:LP600 LOBOY, 230/240V: LP600/700 HIBOY	1	16F575	LABEL, FRONT, LP600 (not shown)	
2	331273 FRAME,LP540 HD	1	16F576	LABEL, RIGHT, LP600 (not shown)	
3	16F551 FASTENER,THREAD,EXTERNAL	4	16F577	LABEL, LEFT, LP600 (not shown)	
4	866356 SPACER,SPACER .75 LG PVC	2	16F735	LABEL, FRONT, MUSTANG 5100 (not shown)	
5	867736 WHEEL,10" X 3.5"	2	16F737	LABEL, RIGHT, MUSTANG 8100 (not shown)	
6	143029 COLLAR,SCREW,SET (SPECIAL ID)	2	16F736	LABEL, FRONT, MUSTANG 8100 (not shown)	
7	331048 BOOT,RUBBER BOOT	2	16F738	LABEL, LEFT, MUSTANG 8100 (not shown)	
77	HOSE 1/4X50'		16K914	LABEL, RIGHT, LP500 (not shown)	
HSE1450 (120V/230V)		1	16K915	LABEL, LEFT, LP500 (not shown)	
865674 (230/240V & 110V)		1	16H949	LABEL, FRONT, LP700 (not shown)	
78	GUN		16H950	LABEL, RIGHT, LP700 (not shown)	
			16H951	LABEL, LEFT, LP700 (not shown)	

Control Parts Diagram

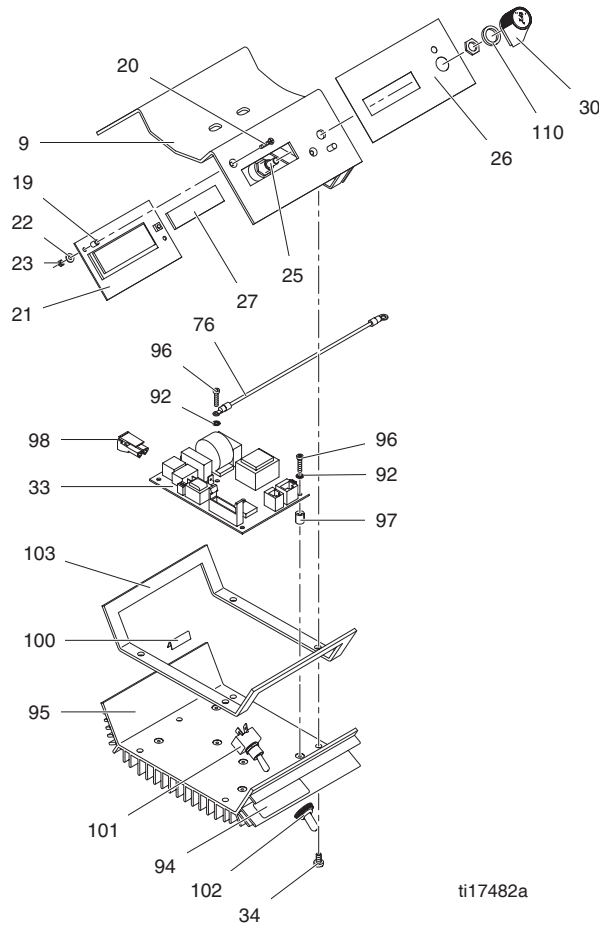

ti17482a

Ref.	Part	Description	Qty	Ref.	Part	Description	Qty
9	867800	BOX,TERMINAL BOX WELDMENT	1	96*		SCREW,MACH,PHILLIPS PAN HD	6
19	117281	SPACER,#6 X .312	2	97*		SPACER,CONTROL BOARD	6
20*	867816	SCREW,MACH,PHILLIPS FLAT HD	2	98*		CONNECTOR,ELECTRICAL	1
21*		DISPLAY,LCD	1			MOTOR	
22*	867731	WASHER,PLAIN-1/8IN.IDX5/16IN.O D	2	100	331296	GUARD,SPLASH	2
23*	867817	NUT,HEX	2	101*	301083	SWITCH,TOGGLE	1
25	256219	POTENTIOMETR,ASSEMBLY	1	102*	301150	BOOT,RUBBER,BLACK	1
26	867804	LABEL,CONTROL,LP	1	103*	867797	GASKET,COVER LP	1
27*	867798	DISPLAY,WINDOW	1	110	15C973	GASKET	1
30	116167	KNOB,POTENTIMETER	1	*	867822	CONTROL BOARD KIT (110/120V)	
33*	867965	CONTROL,BOARD, 110V/120V	1		867823	CONTROL BOARD KIT (230/240V)	
	867966	CONTROL,BOARD, 230V/240V bar	1			KIT, Upgrade from old control board to new control board	
	867967	CONTROL,BOARD, 230V/240V psi	1		867826	With display (110/120V)	
34	331342	SCREW,MACH,PANHEAD	4		867827	With display (230/240V)	
76	866049	CABLE,ASSY 9" LG	1		867828	Without display (110/120V)	
92*	100272	WASHER,LOCK	6		867829	Without display (230/240V)	
94	342513	LABEL,LABEL OFF-ON	1				
95*		HEAT SINK,MACHINED LP	1				

Motor and Drive Parts Diagram

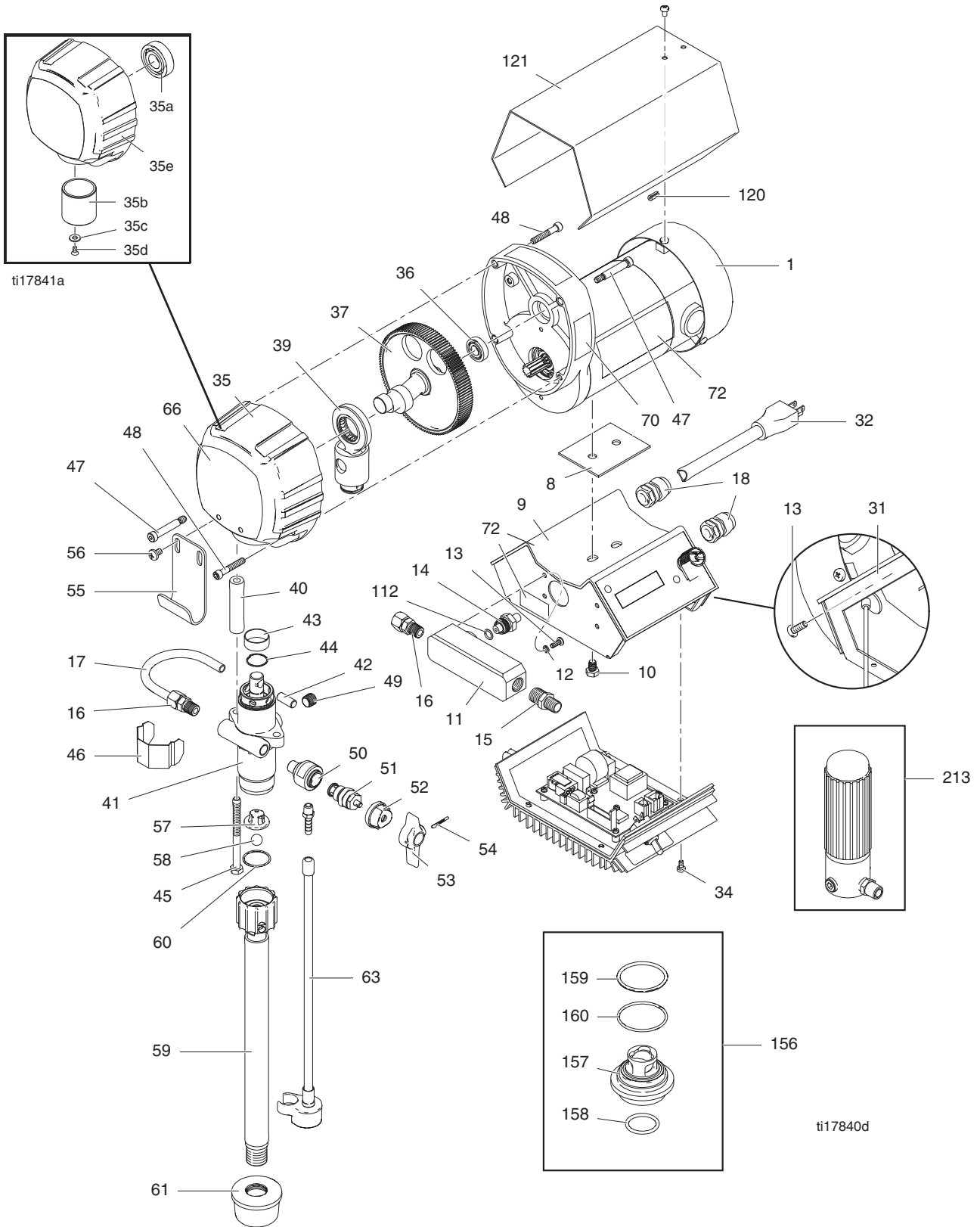

Drive Parts

Ref. Part	Description	Qty	Ref. Part	Description	Qty
1	MOTOR		44 331062	SPRING,RET. SPRING	1
	331490 0.5HP, 110V: LP500 HIBOY/STAND, LP400 STAND	1	45 867539	SCREW,5/16-18 X3.75 HX HD	2
	331491 1HP, 110V: LP600/700 HIBOY, 120V; LP500/600 & MUSTANG 5100/8100	1	46 331111	COVER - GUARD	1
	331492 0.5 HP, 230V: LP500 LOBOY, 240V: LP500 HIBOY, 230/240V: LP400/500 STAND	1	47 866338	SCREW, SHOULDER	2
	331493 1HP, 230V; LP600 LOBOY, 230/240V: LP600/700 HIBOY	1	48 107445	SCREW, CAP	2
1a	331785 FAN	1	49 557391	PLUG	1
1b	331786 FAN COVER	1	50* 865013	ADAPTER, VALVE	
1c	331787 BOLT	1	51* 239913	VALVE, DRAIN	
8	867243 GASKET,SEAL	1	52* 867102	CAM, PRIMING VALVE	
9	867800 BOX,TERMINAL BOX WELDMENT	1	53* 867263	HANDLE, PRIMING VALVE	
10	15V909 SCREW,M8X12	2	54* 867404	PIN, GROOVED	
11	867813 MANIFOLD	1	55 331336	HOOK,PAIL HIBOY	1
12	100020 WASHER,LOCK	4	56 113783	SCREW,MACH,PNH HIBOY	2
14	243222 KIT, REPAIR, TRANSDUCER	1	57 331029	RETAINER,PUMP	1
15	867309 FITTING (UNITS WITHOUT FILTER)	1	58 331030	BALL .500 GR100 ...SS 440	1
	867311 FITTING, (UNITS WITH FILTER)	1	59++	TUBE,SUCTION,SUBASSEMBLY	1
17❖	331364 TUBE, ASSY 3-1/4"	1	60 108526	PACKING,O-RING	1
	867892 TUBE, ASSY 2-1/4"	1	61++	STRAINER, HIBOY	1
18	331185 VALVE,STRAIN RELIEF	2		187651 STRAINER, STAND & LOBOY	1
31	116969 NUT. LOCK	1	63 301348	BYPASS LINE ASSY	1
32	POWER CORD		66 342467	LABEL FRONT LP AIRLESSCO	1
	331163 (120V)	1	70 342524	LABEL- PRIME/SPRAY	1
	867427 (230V)	1	72 ▲	LABEL - WARNING	1
	301101 (240V)	1	195793▲	LABEL - (120V)	1
	118046 (110V)	1	195792▲	LABEL - (230V)	1
34	331342 SCREW,MACH,PANHEAD	9	16G596▲	LABEL - (240V, 110V)	1
35	866477 COVER,FRONT,ASSEMBLY (Includes 35a, 35b, 35c)	1	112 111457	O-RING	1
35a	331046 BEARING	1	120 331178	TRIM EDGE	2
35b	331061 SLEEVE BEARING	1	121 331795	COVER (LP600/8100 & LP700)	1
35c	331103 WASHER	2	156 331051	KIT SUCTION SEAT ASSY	1
35d	331197 SCREW	2	213 866480	KIT,FILTER W/FITTINGS (MUSTANG 5100/8100, LP500/600/700 HIBOY, LP600 LOBOY, LP500 STAND 110/120V)	1
35e	331234 COVER, BARE	1			
36	331047 BEARING,BALL	1			
37	GEAR,CRANK				
	331406 .21 (LP400)	1			
	331407 .26 ASSY (MUSTANG 5100, LP500)	1			
	331593 (LP600 -230/240V & 110V)	1			
	331590 (MUSTANG 8100, LP600 - 120V & 230V LP700)	1			
39	331038 YOKE,CROSSHEAD ASSY	1			
40	331074 SPACER 2.691 LONG	2			
41	866482 PUMP,PAINT,ASSY	1			
42	866082 PIN,CROSS PIN .375	1			
43	331117 SLEEVE	1			

* Included in 866428 Valve Relief Kit

++ Included in 331284 Hi-Boy Suction Assy

▲ Additional warning labels are available at no cost.

❖ Older machines use tube with approximately 2-1/4" center to center distance. Newer machines use wider spaced tube with approximately 3-1/4" center to center distance. Measure connection points to order correct part.

Packing Replacement

Ref.	Part	Description	Qty
1*	331014	MALE GLAND	2
2*	331016	PACKING POLYETHYLENE	6
3*	331308	FEMALE ADAPTOR	1
4	331011	FLUID PUMP BODY	1
5	331029	SUCTION BALL GUIDE	1
6*	331030	SUCTION BALL	1
7*	108526	O-RING	1
8	331292	SUCTION SEAT (HI-BOY)	1
	331051	SUCTION SEAT (LO-BOY)	1
9	331034	SUCTION NUT	1
10+	331314	OUTLET SEAT RETAINER	1
11+	331026	OUTLET SEAT	1
12+*	111457	O-RING	1
13+*	331027	OUTLET BALL	1
14+		PISTON	1
15*	331018	SPACER	1
16*	331025	WASHER, SPRING	3
17*	331022	MALE GLAND	1
18*	331023	PACKING POLYETHYLENE	3
19*	331021	FEMALE GLAND	1
20	331019	PACKING HOLDER	1
21	331037	PACKING NUT	1
22*	331307	PACKING LEATHER	2
23*	331306	PACKING LEATHER	4
24*	107313	WHITE O-RING	1
25*	108771	BLACK O-RING	1
26	180656	PLUG, BUTTON	1
157**		SEAT, SUCTION SEAT	1
158**‡		PACKING, O-RING	1
159**‡		PACKING, O-RING	1
160**‡		RING, BACKUP	1
*	331210	PACKING KIT	
+	331093	PISTON ASSEMBLY	
**		Included in 331051	
‡		Included in O-Ring Kit 16W484	

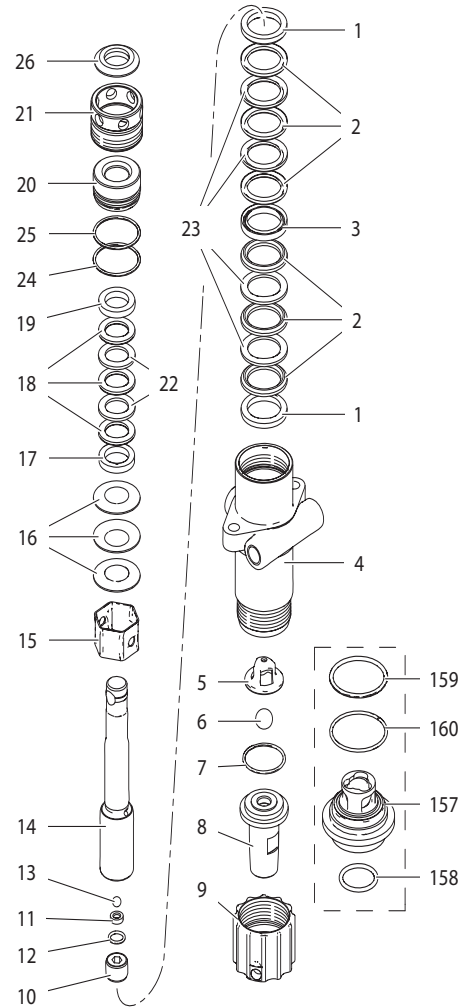

ti16056b

Gearbox Sleeve Bearing Replacement

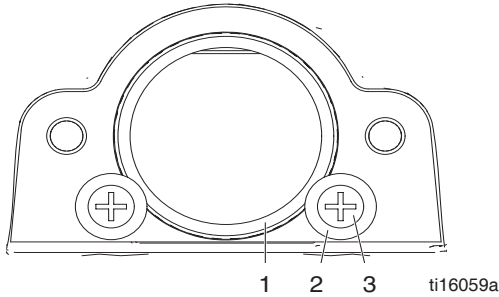

Ref.	Part	Description	Qty
1	331061	SLEEVE BEARING	1
2	331103	WASHER	2
3	331197	SCREW	2

NOTE: When replacing item (1), cover outside of sleeve with 6 drops of Loctite 246 prior to inserting into cover assembly.

Suction Assemblies

Lo-Boy and Carry Chassis (865717)

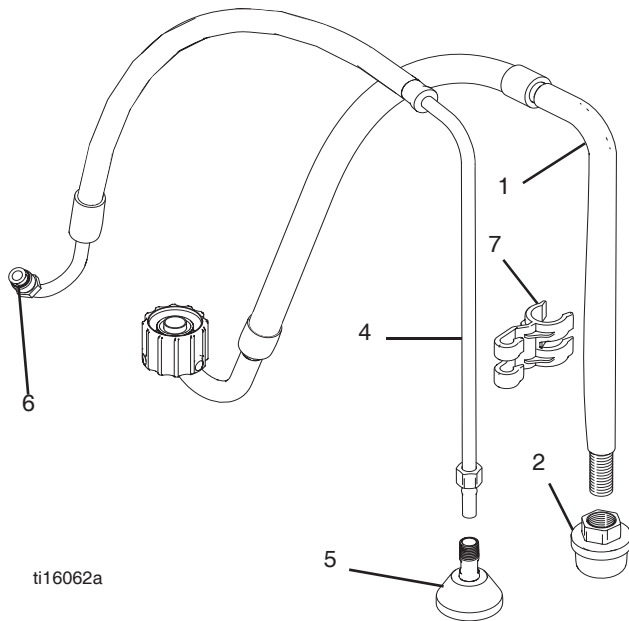

Ref.	Part	Description	Qty
1	331290	SUCTION HOSE ASSEMBLY	1
2	187651	INLET STRAINER	1
4*		DRAIN HOSE	1
5*	241920	THREADED DEFLECTOR	1
6*	867759	MALE CONNECTOR	1
7*	276888	DRAIN LINE CLIP	1

* Sold in Kit 865721

Hi-Boy Chassis (331284)

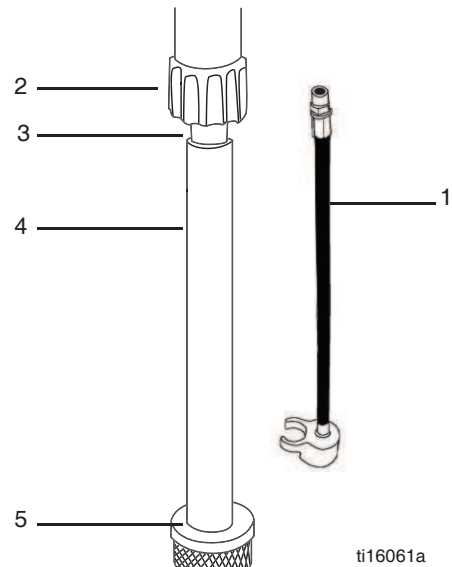

Ref.	Part	Description	Qty
1	301348	BYPASS HOSE ASSEMBLY	1
2	331034	SUCTION NUT	1
3	331292	SUCTION SEAT ASSEMBLY	1
4	331400	INLET TUBE	1
5	187190	INLET STRAINER	1

Electrical System

120V

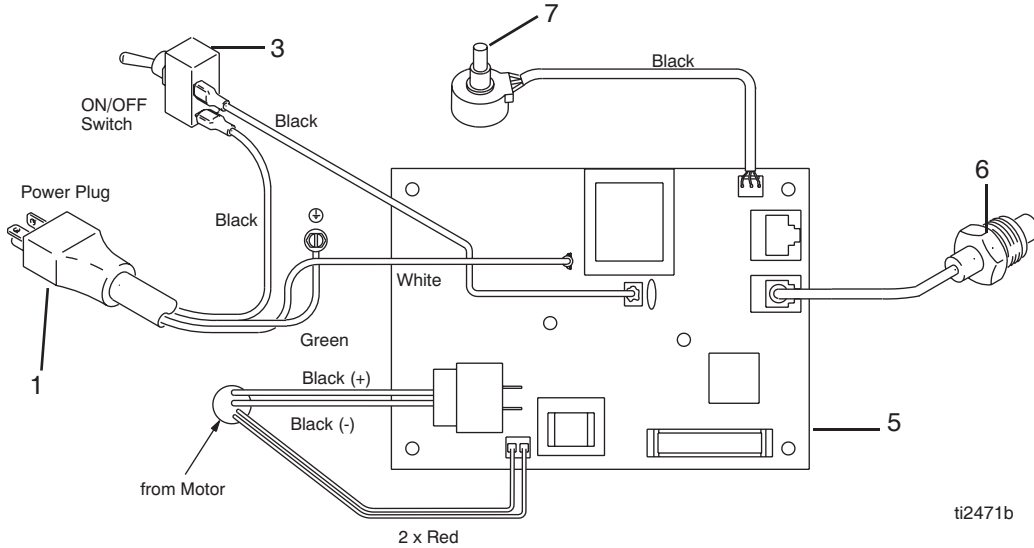

230V

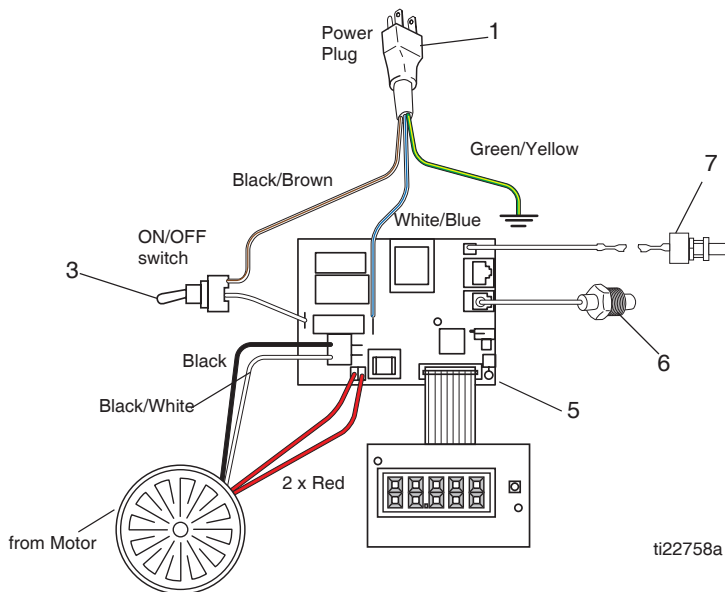

Ref.	Part	Description	Qty	Ref. Part	Description	Qty
1		POWER CORD	1	3	301083 TOGGLE SWITCH	1
	331163	(120V)	1	5	PRESSURE CONTROL ASSEMBLY	1
	867427	(230V)	1	6	KIT, REPAIR TRANSDUCER	1
	301101	(240V)	1	7	POTENTIOMETER	1
	118046	(110V)	1	8▲	15T069 LABEL,WARNING (120V)	1
					15H087 LABEL,WARNING (230V)	

▲ Additional warning labels are available at no cost.

Electrical Components

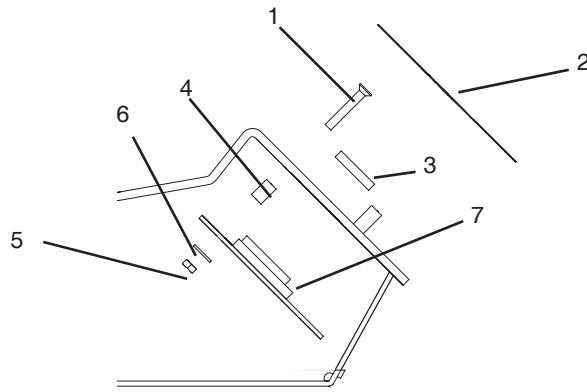

ti16066a

Ref.	Part	Description	Qty	Ref.	Part	Description	Qty
1	867816	SCREW	2	5	867817	NUT	2
2	867804	LABEL, PRESSURE CONTROL	1	6	867731	WASHER	2
3	867798	WINDOW	1	7		LCD DISPLAY (PSI)	1
4	117281	SPACER	2		867821	LCD DISPLAY Kit (PSI) Includes 1, 3, 4, 5, 6, 7	1

Technical Data

LP400/500/600/700, Mustang 5100/8100		
	US	Metric
Power requirements	120V AC, 60 hz, 11A, 1 phase	
	230V AC, 50/60 hz, 7.5A, 1 phase	
Generator required	3000 w minimum	
Maximum working pressure	3000 psi	21 MPa, 207 bar
Maximum delivery		
LP400	0.46 gpm	1.75 lpm
LP500	0.54 gpm	2.0 lpm
LP600 (International)	0.66 gpm	2.5 lpm
LP700	0.74 gpm	2.8 lpm
LP600 (North America)	0.85 gpm	3.2 lpm
Maximum tip size		
LP400	0.021	
LP500	0.023	
LP600 (International)	0.025	
LP700	0.027	
LP600 (North America)	0.027	
Fluid outlet npsm	1/4 inch	
Noise (dBa)		
Sound pressure	80 dBa	
Wetted parts	zinc and nickel-plated carbon steel, nylon, stainless steel, PTFE, acetal, leather, UHMWPE, aluminum, tungsten carbide	
Notes		
Sound pressure measure at 3.1 feet (1 meter) from equipment.		

Airlessco Standard Warranty

Airlessco warrants all equipment referenced in this document which is manufactured by Airlessco and bearing its name to be free from defects in material and workmanship on the date of sale to the original purchaser for use. With the exception of any special, extended, or limited warranty published by Airlessco, Airlessco will, for a period of twelve months from the date of sale, repair or replace any part of the equipment determined by Airlessco to be defective. This warranty applies only when the equipment is installed, operated and maintained in accordance with Airlessco's written recommendations.

This warranty does not cover, and Airlessco shall not be liable for general wear and tear, or any malfunction, damage or wear caused by faulty installation, misapplication, abrasion, corrosion, inadequate or improper maintenance, negligence, accident, tampering, or substitution of non-Airlessco component parts. Nor shall Airlessco be liable for malfunction, damage or wear caused by the incompatibility of Airlessco equipment with structures, accessories, equipment or materials not supplied by Airlessco, or the improper design, manufacture, installation, operation or maintenance of structures, accessories, equipment or materials not supplied by Airlessco.

This warranty is conditioned upon the prepaid return of the equipment claimed to be defective to an authorized Airlessco distributor for verification of the claimed defect. If the claimed defect is verified, Airlessco will repair or replace free of charge any defective parts. The equipment will be returned to the original purchaser transportation prepaid. If inspection of the equipment does not disclose any defect in material or workmanship, repairs will be made at a reasonable charge, which charges may include the costs of parts, labor, and transportation.

THIS WARRANTY IS EXCLUSIVE, AND IS IN LIEU OF ANY OTHER WARRANTIES, EXPRESS OR IMPLIED, INCLUDING BUT NOT LIMITED TO WARRANTY OF MERCHANTABILITY OR WARRANTY OF FITNESS FOR A PARTICULAR PURPOSE.

Airlessco's sole obligation and buyer's sole remedy for any breach of warranty shall be as set forth above. The buyer agrees that no other remedy (including, but not limited to, incidental or consequential damages for lost profits, lost sales, injury to person or property, or any other incidental or consequential loss) shall be available. Any action for breach of warranty must be brought within two (2) years of the date of sale.

AIRLESSCO MAKES NO WARRANTY, AND DISCLAIMS ALL IMPLIED WARRANTIES OF MERCHANTABILITY AND FITNESS FOR A PARTICULAR PURPOSE, IN CONNECTION WITH ACCESSORIES, EQUIPMENT, MATERIALS OR COMPONENTS SOLD BUT NOT MANUFACTURED BY Airlessco. These items sold, but not manufactured by Airlessco (such as electric motors, switches, hose, etc.), are subject to the warranty, if any, of their manufacturer. Airlessco will provide purchaser with reasonable assistance in making any claim for breach of these warranties.

In no event will Airlessco be liable for indirect, incidental, special or consequential damages resulting from Airlessco supplying equipment hereunder, or the furnishing, performance, or use of any products or other goods sold hereto, whether due to a breach of contract, breach of warranty, the negligence of Airlessco, or otherwise.

FOR AIRLESSCO CANADA CUSTOMERS

The Parties acknowledge that they have required that the present document, as well as all documents, notices and legal proceedings entered into, given or instituted pursuant hereto or relating directly or indirectly hereto, be drawn up in English. Les parties reconnaissent avoir convenu que la rédaction du présente document sera en Anglais, ainsi que tous documents, avis et procédures judiciaires exécutés, donnés ou intentés, à la suite de ou en rapport, directement ou indirectement, avec les procédures concernées

TO PLACE AN ORDER OR FOR SERVICE, contact your Airlessco distributor,
or call 1-800-223-8213 to identify the nearest distributor.

*All written and visual data contained in this document reflects the latest product information available at the time of publication.
Airlessco reserves the right to make changes at any time without notice.*

For patent information, see www.graco.com/patents.
Original Instructions. This manual contains English. *MM 3A1185*

AIRLESSCO • 3501 N. 4th AVENUE • SIOUX FALLS, SD 57104 • USA

Copyright 2010, Airlessco. All Airlessco manufacturing locations are registered to ISO 9001.

Revised January 2014